

F9J GCB

BCHG

% 7 F9DF9G9BH5 7F#7 5@8A 9BGC B"
&"A-B AIA DI G-CI H: CF7 9."+) @G
**D5F1GHC 69D57?5: 98-B HF5MG
("AIGH697 <97?98 CB 9J 9FM* 7C BG97I HJ 9D-BG

8D5: !&!\$' "\$!L!L!L
f5@7C BH57 HGBC HG<CK B: CF 7 @F#M

8D5: !LL!\$' "\$!L!L!L

Bc' C: DC GHC BG
!\$(z!\$*z!\$, z!%) z!& z!'
fD9F FCK L

C DHC B
!5. 5@ BA 9BHD B
fB99: = "%&G-H' L
!?. ?5DHC B D58
fG99: = "' zG-H' L
!H: H5D9/ F99@

8C BCH
G7 5@: FCA
H-GDF BH

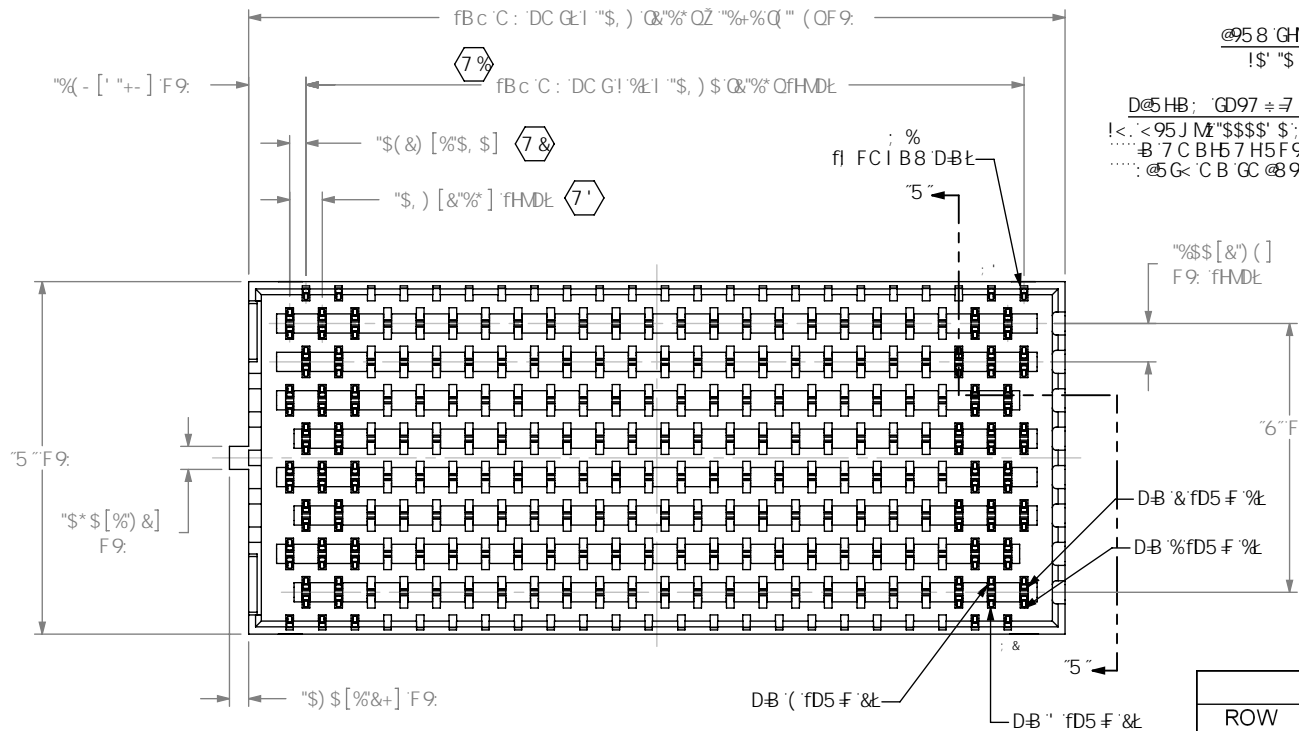

@958 GHM@
!\$' "\$

D@5HB: GD97 = 7 5HC B
!<. <95 J MZ "\$\$\$\$ '\$: C @
B 7 C BH57 H5F95": C @
@5G< C B GC @9F H5 @

GC @9F 7FA DA 5H9F-5@
!%*' I HB #' + @958
fI G9G 6I7!% %\$' "\$!<!%&
!&-'*") I HB #' I G@ 9F #
.....) I 7C DD9F
fI G9G 6I7!% %\$' "\$!<!&

FCK
! 8=: 9F9BH5@D5 F FCK G
! 8=: 9F9BH5@D5 F FCK G
1 BC HF 9@95 G98 : CF DFC 8I 7HC B

TABLE 1 - ARRAY SIZE TABLE

SIZE	DIFFERENTIAL PAIRS PER ARRAY	
	3 ROW	8 ROW
-04	6 PAIRS	16 PAIRS
-06	12 PAIRS	32 PAIRS
-08	18 PAIRS	48 PAIRS
-15	39 PAIRS	104 PAIRS
-23	63 PAIRS	168 PAIRS
-30	84 PAIRS	N/A

TABLE 2

ROW	"A"	"B"	"C"
-8	.918[23.32]	.700[17.78]	.209[5.31]
-3	.418[10.62]	.200[5.08]	.096[2.44]

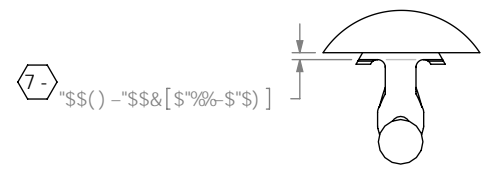
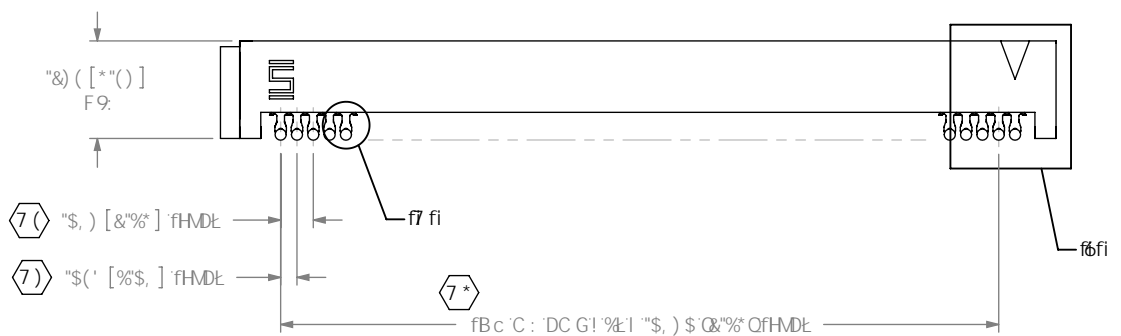

8 9H5 @f7 fi
G7 5@, . %
f5@7C BH57 HGBC H
G<CK B: CF 7 @F#M

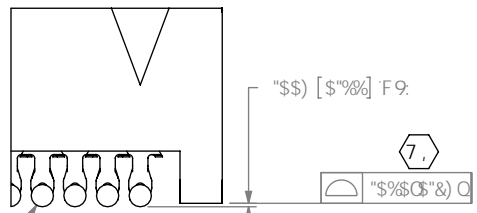

RCVGP V'P WO DGTU
8; 9; 45: "T9359: 54
8; 8; 4: 8" T939: 454
937: 534" T939465:
9274559" T93474; 5

I B @9G C H: 9FK @9 GD97 = 98Z
8A 9BGC BG5F9-B B7 <9G
HC @9F5B7 9G 5F9.
897 A 5@5B: @9G
"LL. + "\$%0" O&
"LLL. + "\$\$) 0% O
"LLLL. + "\$\$\$& OS) %

DFC DF-9H5 FMBC H
H: @8C 71A 98H7C BH5 8G B: CFA 5HC B
7C B: @9B H5 @588 DFC DF-9H5 FMC
G5A H7 Z B7 *5B8 G: 5@B C H: 9F 90FC 8I 7 98
CF H5BG 9F98 HC C H: 9F 8C 71A 9BHGCF
8 47 @C 98 HC C H: 9F GCF I 98: CF 5BM
DI FDC @9C H: 9F H5B H: 5HK <7 < H: 5G
C 6H5 898 K H: C I H: 99L DF 9998 K F H98
7C B@98 HC: G5A H7 Z B7 *

A 5H9F-5@ 8C BCH G7 5@ 8F5K B: G: 99HG7 5@. %&
BGI @5HC F. @7 D'27 C @C F. 6@57?
7C BH57 HC F H9FA B5@ 7C DD9F 5@C M

&\$ D5F? 95GH6@ 8ZB9K 5@5BMB (+) % \$
D<C B9; %&L - ((! + *) %& - () \$ (+
YIA UJ; . b z 4 G5A H7 Wca WXY.)) &&

89G7 F@HC B.
" \$,) D#7 < 8D' GC 7? 9H5 GG9A 6@M
8K: "BC"
8D5: !LL!\$' "\$!L!L!L
6M 7 < 58: \$* # \$ * # & \$ \$' G< 99H% C: '

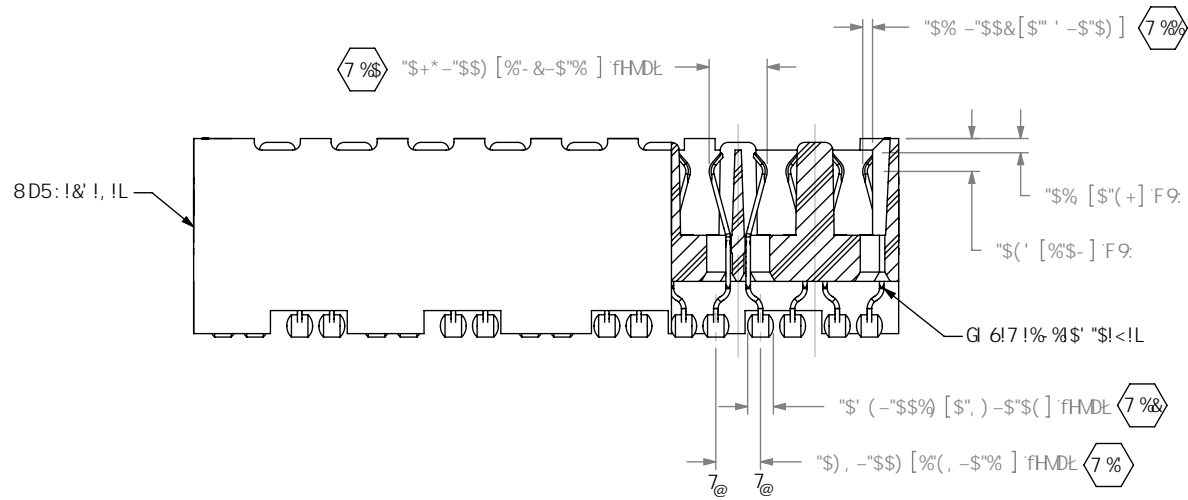

G97 H€ B `5 1 5 "
G7 5@?` (%

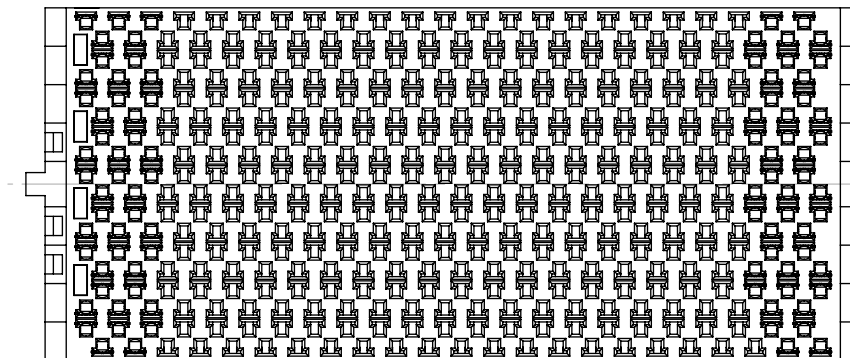

f6CHCA 'J -9K 'DFC >97 H98 : FCA 'G<99H%L
 f5 @@7 C.B!57 HGBC HG<C K B: CF 7 @5F #M€

<p>DFC.DF-9!5 FMBC!9 H: €8C 7!A 98!7 C B!5 BG B: CFA 5HC B 7 C B: @98!5 9588 DFC DF 945 F!M€ GSA H97 2 8 7 *588 G-588BC H69 F90FC 81 7 98 CF !F58G 9F98 HC C!H: 9F 8C 7!A 98!6C F 8 47 @C 998 !C C!H: 9FGC F! 998 : CF 58M DI FDC 99 C!H: 9F !H: 5B !H: 5HK <7 < #!K 5G C 6!5 8 98 K #<C ! !H: 9 9!DF 90998 K F #!98 7 C B 998 HC : GSA H97 2 8 7 *</p>	 <p>)&\$ D5F? 95GH6@ 8ZB9K 5 @5BM-B (+) \$ D<C B 9 ; %&L - ((! * + 5L ; %&L - (,) \$ (+ YIA UJ ; b z 4 GSA H97 Wc a W€XY .))' &&</p>
<p>8C 'BCHG7 5 @9 8F5K B;</p>	<p>89G7 F @HC B. "\$,) 'D#7 < '8 D'GC 7 ? 9H5 GG9A 6 @M</p>
<p>G: 99HG7 5 @9 & %</p>	<p>8K : "BC" 8D5: !LL!\$' "\$!L!L!L!L</p>
<p>:.P8K : PA 67 PA ?H P8D5: ILLI\$ 'SILILILLIA ?HG88FK</p>	<p>6M 7 < 58 : \$* # \$ * # & \$ \$ ' G< 99H & C : '</p>

: ± ""&
 8D5: !& !\\$ "!\\$<!, !%5'G<CK B
 fG5A 9'5G: ± ""%Z9L7 9DH5GG<CK BŁ
 C@7CBH57HGBC HG<CK B': CF'7 @5F#MĐ

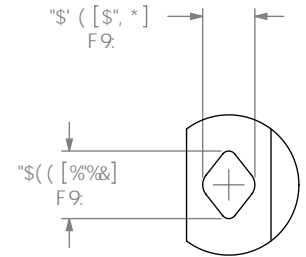
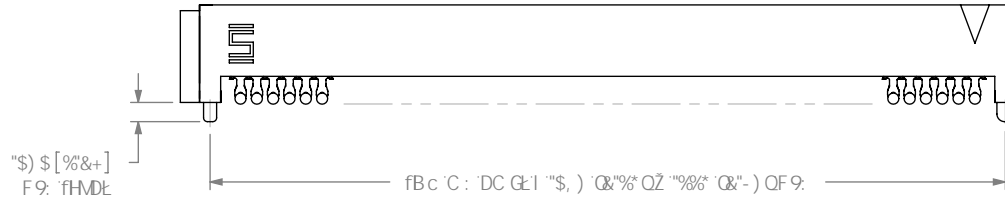

8 9H5 @f9fi
 G7 5 @, .:9

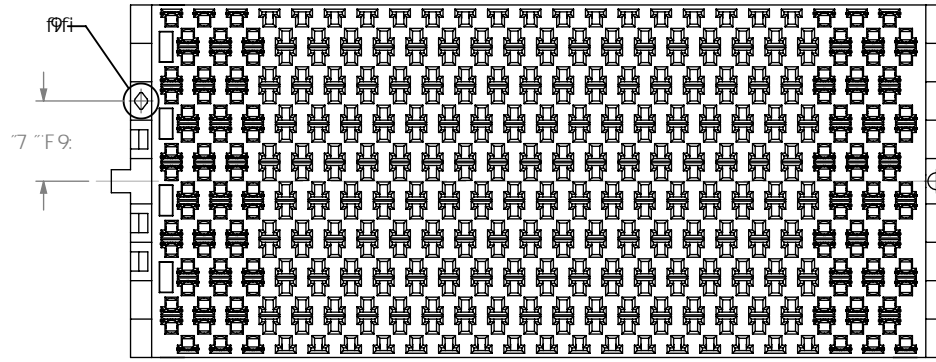

: ± ""
 8D5: !& !\\$ "!\\$<!, !%5!?'G<CK B
 fG5A 9'5G: ± ""%Z9L7 9DH5GG<CK BŁ
 fB @7CBH57HGBC HG<CK B': CF'7 @5F#MŁ

TABLE 3			
ROW	# OF POSITIONS	DIA "D"	DIM "E"
-3	4,6,8,15,23,30	.30[7.5]	"E" = (No OF POS x .085[2.16] + .171[4.34] - "D") /2
-8	4,6	.30[7.5]	
-8	8,15,23,30	.80[20.3]	

"& - [*) ,]

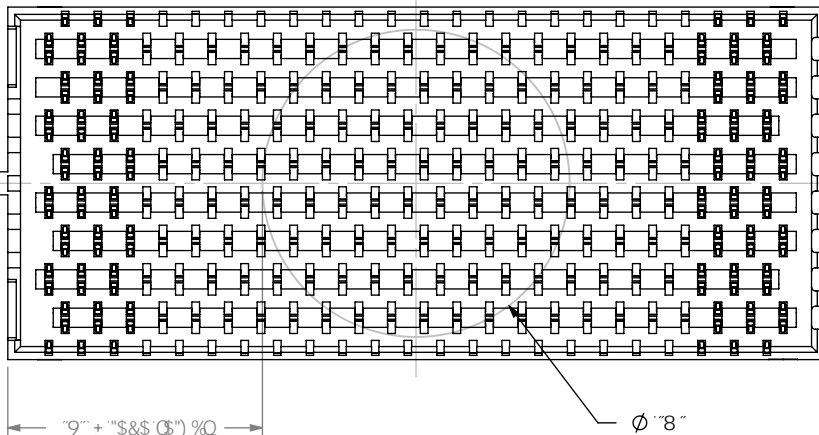

?!%\$\$\$!, \$\$

:.PBK : PA 67PA ?H PB85: ILLI\$ "SILILILLIA ?HG88FK

DFC.DF-9H5.FMBC.H9

H: €8C71A 98H7CBH5BG B: CFA 5HC B
 7CB: @98H595B8 DFC DF 945FHMŁ
 GSA H97 2 87 558 G-588BC H69 F90FC 81 798
 CF HF58G 9F98 HC CH: 9F 8C 71A 98HGCF
 8 47 @G98 HC CH: 9FGCF I G98 : CF 58M
 DI FDC @9 CH: 9F H: 5B H: 5HK <7 < #HK 5G
 C 6H5 B 98 K #C1 H: 9 9LDF 9G98 K F #H8
 7CB98HC: GSA H97 2 87 "

8C 'BCHG7 5 @9 8F5K -B:
 G: 99HG7 5 @9 &%

)&\$ D5F? 95GH6@ 8zB9K 5 @5BM-B (+%) \$
 D<C B 9 ; %&L - ((! * + SL ; %&L - () \$ (+
 YIA UJ ; b z 4 GSA H97 "Łca WŁXY.))' &&

89G7 F @HC B.
 "\$,) 'D#7 < 8D'GC 7 ?9H5GG9A 6 @M
 8K : ""BC"
8D5: !LL!\$' "\$!L!L!L!L

6M 7 < 58: \$* # \$ * # & \$ \$ ' G< 99H''C: '